

# OPERATION MANUAL

## TAMPING RAMMER SG70 /SG80 /TR65



**WARNING**

To reduce the risk of injury, all operators and maintenance personnel must read and understand these instructions before operating, changing accessories, or performing maintenance on this power equipment. All possible situations cannot be covered in these instructions. Care must be exercised by everyone using, Maintaining or working near this equipment..

## Table of Contents

<b>1. SAFETY INFORMATION</b> .....	2
1.1 Safety Precautions .....	2
1.2 Operating Safety.....	3
1.3 Operator Safety while using Internal Combustion Engines.....	4
1.4 Service Safety .....	5
1.5 Label Locations.....	6
1.6 Safety and Operating Labels.....	7-9
<b>2. OPERATION</b> .....	10
2.1 Application.....	10
2.2 Structure .....	10
2.3 Before Starting.....	10
2.4 To Start .....	11
2.5 Operation.....	12
2.6 To Stop .....	12
<b>3. MAINTENANCE</b> .....	13
3.1 Periodic Maintenance Schedule.....	13
3.2 Transporting .....	14
3.3 Spark Plug.....	14
3.4 Air Cleaner.....	15
3.5 Storage .....	15
3.6 Trouble Shooting.....	15-17
<b>4. TECHNICAL DATA</b> .....	18
<b>WARRANTY</b> .....	19
<b>MAINTENANCE RECORD</b> .....	20

## SAFETY INFORMATION

### 1.1 Safety Precautions

Before using this equipment, study the entire owner's manual to become familiar with its operation. Do not allow untrained or unauthorized personnel, especially children, to operate this equipment. Use only factory authorized parts for service.

This manual contains DANGER, WARNING, CAUTION callouts which must be followed to reduce the possibility of personal injury, damage to the equipment, or improper service.



This is the safety alert symbol. It is used to alert you to potential personal injury hazards. Obey all safety messages that follow this symbol to avoid possible injury or death.



**DANGER**

DANGER indicates a hazardous situation which, if not avoided, will result in death or serious injury.



**WARNING**

WARNING indicates a hazardous situation which, if not avoided, could result in death or serious injury.



**CAUTION**

CAUTION indicates a hazardous situation which, if not avoided, could result in minor or moderate injury.

## SAFETY INFORMATION

### 1.2 Operating Safety

Familiarity and proper training are required for the safe operation of equipment! Equipment operated improperly or by untrained personnel can be dangerous! Read the operating instructions and familiarize yourself with the location and proper use of all instruments and controls. Inexperienced operators should receive instruction from someone familiar with the equipment before being allowed to operate the rammer.

- **NEVER** operate rammer in applications for which it is not intended.
- **NEVER** allow improperly trained personnel to operate rammer.
- **NEVER** touch hot muffler, engine cylinders, or cooling fins. Burns will result.
- **NEVER** use accessories or attachments which are not recommended by TEKPAC for rammer. Damage to rammer and/or injury to user may result.
- **NEVER** leave a running machine unattended.
- **NEVER** run machine indoors or in an enclosed area such as a deep trench unless adequate ventilation is provided. Exhaust gas from the engine contains poisonous carbon monoxide gas; exposure to carbon monoxide can cause loss of consciousness and may lead to death.
- **NEVER** tamper with or disable the function of operating controls.
- **NEVER** use choke to stop engine.
- **NEVER** operate the machine in areas where explosions may occur.
- **ALWAYS** remove or disconnect engine spark plug before servicing rammer, to avoid accidental start-up.
- **ALWAYS** read, understand, and follow procedures in Operation Manual before attempting to operate equipment.
- **ALWAYS** be sure that all other persons are at a safe distance from the rammer. Stop the machine if people step into the working area of the machine.
- **ALWAYS** be sure operator is familiar with proper safety precautions and operation techniques before using rammer.
- **ALWAYS** wear protective clothing when operating rammer. Wear goggles or safety glasses, hearing protection, and safety shoes.
- **ALWAYS** keep hands, feet, and loose clothing away from moving parts of rammer.
- **ALWAYS** use common sense and caution when operating rammer.
- **ALWAYS** be sure rammer will not tip over, roll slide, or fall when not being operated.
- **ALWAYS** turn engine OFF when rammer is not being operated.
- **ALWAYS** guide the rammer in such a way that the operator is not squeezed between the rammer and solid objects. Special care is required when working on uneven ground or when compacting coarse material. Make sure to stand firmly when operating the machine under such conditions.
- **ALWAYS** operate the rammer in such a way that there is no danger of it turning over or falling in, when working near the edges of breaks, pits, slopes, trenches and platforms.

## SAFETY INFORMATION

### 1.3 Operator Safety while using Internal Combustion Engines

- DO NOT smoke when refueling the engine or during any other fuel handling operation.
- DO NOT refuel a hot or running engine.
- DO NOT refuel the engine near an open flame.
- DO NOT spill fuel when refueling the engine.
- DO NOT smoke while operating rammer.
- DO NOT operate rammer near open flames.
- ALWAYS refill fuel tank in well-ventilated area.
- ALWAYS replace fuel tank cap after refueling.
- ALWAYS check fuel lines, fuel cap, and fuel tank for leaks and cracks before starting engine. Do not run machine if fuel leaks are present, or fuel cap or fuel lines are loose.
- If fuel is spilled during refueling, wipe it off from the engine immediately and discard the rag in a safe place. Do not operate the unit if fuel or oil leaks exist-repair immediately.
- NEVER operate this equipment in an explosive atmosphere.
- NEVER operate any gas powered equipment in a poorly ventilated or enclosed area.
- NEVER perform any work on the unit while it is running. Before working on it, stop the engine and disconnect the spark plug wire to prevent accidental starting.
- Avoid prolonged breathing of exhaust gases.
- Avoid contact with hot exhaust systems and engine parts.
- Allow engine to cool before performing any repairs or service.
- ALWAYS transport and handle fuel only when contained in approved safety containers.
- ALWAYS keep the area around the muffler free of debris such as leaves, paper, cartons, etc. A hot muffler could ignite the debris and start a fire.

## SAFETY INFORMATION

### 1.4 Service Safety

Poorly maintained equipment can become a safety hazard! In order for the equipment to operate safely and properly over a long period of time, periodic maintenance and occasional repairs are necessary.

- DO NOT attempt to clean or service rammer while it is running.
- DO NOT operate rammer with safety devices or guards removed or not in working order.
- DO NOT operate rammer without air cleaner.
- DO NOT remove air cleaner paper element, precleaner, or air cleaner cover while operating rammer.
- DO NOT alter engine speeds. Run engine only at speeds specified in Technical Data Section.
- ALWAYS replace safety devices and guards after repairs and maintenance.
- ALWAYS keep area around muffler free of debris in order to reduce to chance of an accidental fire.
- ALWAYS do Periodic Maintenance as recommended in Operation Manual.
- ALWAYS clean debris from engine cooling fins.
- ALWAYS replace worn or damaged components with spare parts designed and recommended by TEKPAC for servicing this rammer.

# SAFETY INFORMATION



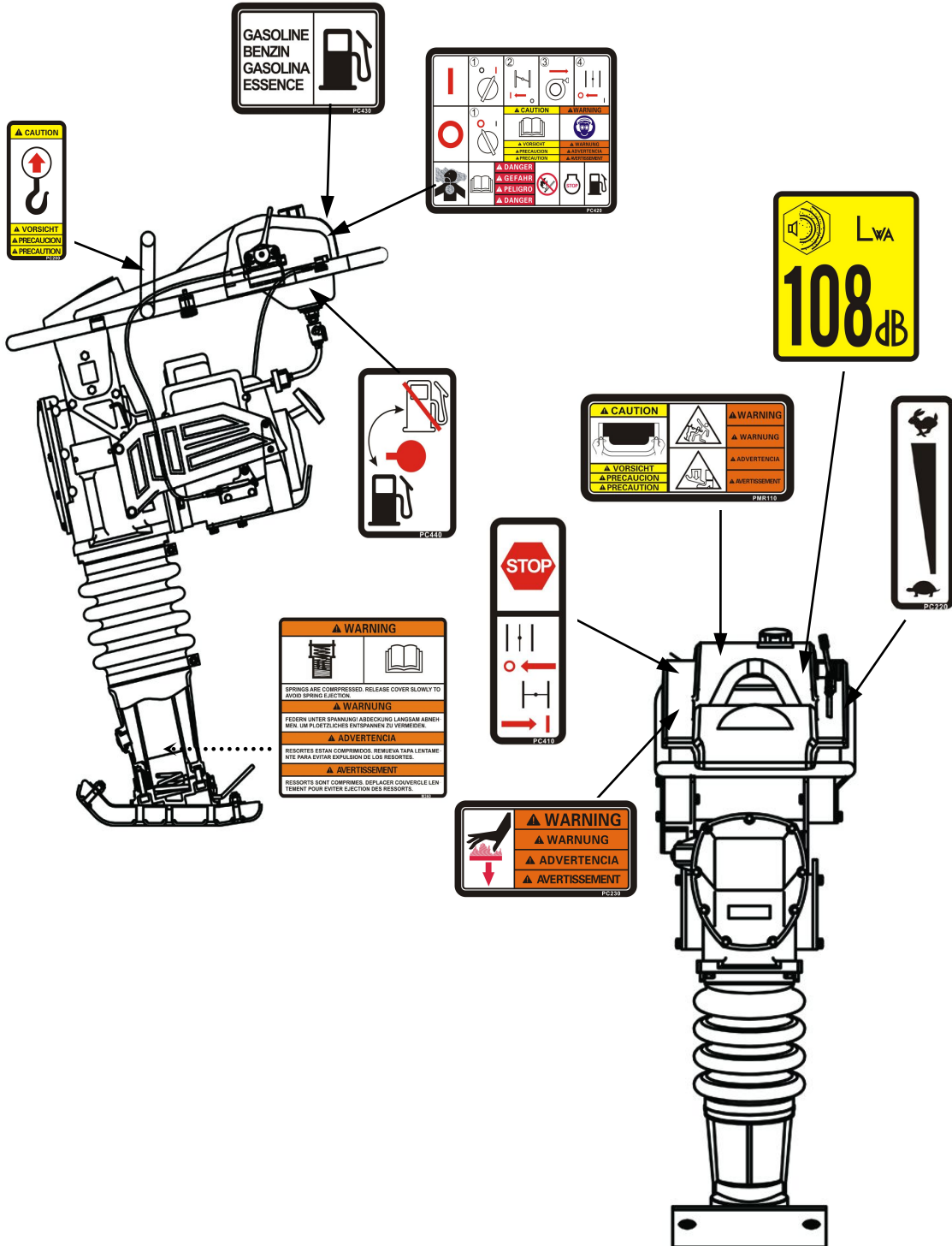

## 1.4 Label Locations



# SAFETY INFORMATION

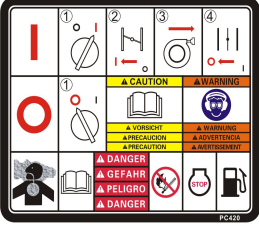

## 1.5 Safety Labels

TEKPAC machines use international pictorial labels where needed. These labels are described below:

Label	Meaning
	<p>This model-in label contains important safety and operating information. If it becomes illegible, the cover must be replaced. Refer to the Parts Manual for ordering information.</p>
	<p><b>DANGER!</b> Engines emit carbon monoxide; operate only in well-ventilate area. Read the Operation Manual for machine information. No sparks, flames, or burning objects near the machine. Shut off the engine before refueling. Use only clean, filtered unleaded gasoline.</p>
	<p><b>CAUTION!</b> Lifting point.</p>
	<p><b>CAUTION!</b> Use only clean, filtered gasoline fuel.</p>
	<p><b>WARNING!</b> Hot surface!</p>

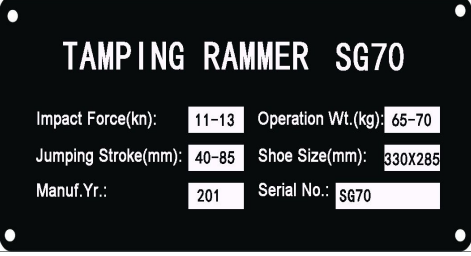

## SAFETY INFORMATION

Label	Meaning
	<p><b>CAUTION!</b> For optimal control, performance, and minimal hand/arm vibration, grasp handle as shown.</p>
	<p><b>WARNING!</b> Serious injury if struck by compressed spring or cover. If the spring system cover is removed improperly, the springs can eject.</p>
	<p>Guaranteed sound power level in dB(A).</p>
	<p>A nameplate listing the model number and serial number is attached to each unit. Please record the information found on this plate so it will be available if the nameplate lost or damaged. When requesting service information, the serial number should be specified of the unit.</p>

## SAFETY INFORMATION

### 1.7 Operating Labels

Our machines use international pictorial labels where needed. These labels are described below:

	<p>Start the engine:</p> <ol style="list-style-type: none"> <li>① Turn the engine switch to the ON position</li> <li>② Close the choke.</li> <li>③ Pull the rewind starter.</li> <li>④ Open the choke.</li> </ol>
	<p>Stop the engine: Turn the engine switch to OFF position.</p>
	<p>Fuel valve: Closed  Open</p>
	<p>Engine stop button: Press to stop engine.</p> <p>Choke: O: Open  I: Closed</p>
	<p>NOTICE! Throttle control lever: Turtle = Idle or Slow Rabbit = Full or Fast</p>

## OPERATION

### 2 Operation

#### 2.1 Application

Rammers are designed to compact loose soils and gravel to prevent settling and to provide a firm, solid base for the placement of footings, concrete slabs, foundations, gas piping works, water pipe works and cable backfill works, etc.



**WARNING**

Please do not use in such as following cases. It may cause damage because machine is likely to be unbalanced.

- Pile foundation
- Hard soil excessively compacted over normal condition
- Steep bank slope

Tamping Rammer is to be used for compacting cohesive clay, gravels, and patching work on asphalt, etc.

#### 2.2 Structure

The upper part is made up of Power source, Clutch, Connecting Rod and Operating Handle, Fuel Tank that connected via Shock Absorbing Rubber to body. Bottom end is made up of Spring Cylinder (Sliding part), Foot Plate that ramps body, Foot and Bellows that covers sliding part.

#### 2.3 Before Starting

- This machine is of oil bath lubrication system.
- Check the oil level through a window at rear end of the foot. Replenish oil if oil is not visible at the window. For lubrication, use automobile engine oil of 10W-30 SE, SF or better grade. Capacity is 830cc.
- Fill the fuel tank with regular gasoline (unleaded). Simultaneously, check engine oil and make it a habit to replenish on the earlier side. Low lubrication oil level may result in engine seizure due to consumption during operation. Nevertheless, oil level should be checked prior to start up without fail. For lubrication, use automobile engine oil of 10W-30 SE, SF or better grade. See Engine Operating Manual for further detail.
- Check every bolt, nut or screwed area for tightness. ***Loosened due to vibration may result in unexpectedly serious trouble. Be sure to tighten any screwed area.***
- Remove dirt and dust. Particularly clean the vicinity of recoil starter and foot.

## OPERATION

### 2.4 To Start

1. Open the fuel shut-off valve by moving the fuel cock level to the open position.
2. Set the engine ON/OFF switch to the "ON" position.
3. Grip the recoil starter handle and pull it until you feel slight resistance. Then pull sharply and quickly. Return the recoil starter handle to the starter case before releasing.
4. Grip the recoil starter handle and pull it a little to feel a slight resistance. Then pull it powerfully from there. To release the handle do not release it at the position where it has been pulled to, but release it after returning closely to the starter case.
5. If the engine has started, while listening to explosion sounds, return the choke lever slowly to full-open position. Be sure to perform a warm-up run for the period 3 to 5 minutes at low speed, while paying careful attention to gas leakage or abnormal sound.
6. If it is difficult to start the engine by repeatedly pulling the starter rope, remove ignition plug and check the sparking performance. If the plug is wet due to excessive fuel intake or soiled, replace the coil or clean sufficiently to its internals. With the ignition plug removed, pull the recoil starter handle 2-3 times to discharge excessive blended gas.

## OPERATION

### 2.5 Operation

1. Turning the choke level to open the choke. Running the engine for 5 minutes at low speed to warm the engine.
2. Move the throttle level quickly to the "FULL OPEN" position. DO NOT move the throttle level slowly as this may cause damage to the clutch or spring.



#### CAUTION

Make sure that the throttle lever is moved to the FULL OPEN position. Operating the rammer at less than full speeds can result in damage to the clutch springs or foot.

3. After starting to tamping action, adjusts the jumping motion to suit particular soil condition by lightly controlling the throttle lever. When the engine speed falls between the set values shown on the engine, your work can be carried out at the best efficiently. Increasing the engine speed unnecessarily, does not cause the compaction force to increase. On the contrary, a resultant resonance causes the compaction force to decrease, damaging the machine.
4. Under cold weather, the oil in the machine being viscous, resistance at reciprocating part is greater causing the tamping rammer to perform somewhat irregular movement. Therefore, it is recommended to perform warm-up run while moving the throttle lever repeatedly between ON and OFF positions, before entering the work.
5. Soil contacting surface of the foot is lined with heat-treated metal sheet for extra strength. However, for compacting cobblestone, use the filling-up soil for example so that the foot hits the soil uniformly.
6. The tamping rammer has been designed to advance while jumping. For quicker advance, erect the machine by pushing its handle down slightly so that flat surface of the foot at its rear-end contacts the ground.
7. To stop the tamping action, move throttle lever quickly from the FULL OPEN to IDLE position.

### 2.6 To Stop

#### 2.6.1 Normal shutdown

1. With the throttle lever closed from ON to OFF, run the engine for 3-5 minutes at low speed, and after temperature is lowered, turn the switch to the "OFF" position.
2. Close the fuel shut-off valve by moving the fuel cock lever to the CLOSED position.

#### 2.6.2 Emergency shutdown

Move the throttle lever quickly to the IDLE position, and turn the engine ON/OFF switch to the OFF position.

## MAINTENANCE

### 3 MAINTENANCE

#### 3.1 Periodic Maintenance Schedule

The chart below lists basic maintenance. Refer to engine manufacturer's Operator's Manual for additional information on engine maintenance. A copy of the engine Operator's Manual was supplied with the machine when it was shipped.

	Daily Before Startin g	After First 5 hours	Every Week or 25 hours	Every month or 100 hours	Every 3 months or 300 hours
Check fuel level.	●				
Check oil level of machine.	●				
Check fuel line and fittings for cracks or leaks.	●				
Tighten ramming shoe hardware.		●	●		
Check and tighten engine cylinder screws.		●	●		
Check and tighten external hardware.		●	●		
Clean engine cooling fins.			●		
Clean and check spark plug gap.			●		
Replace spark plug.				●	
Clean recoil starter.					●
Change ramming system oil. *					●
Clean engine muffler and exhaust port.					●

**\* Change ramming system oil after first 50 hours of operation.**

Note: If engine performance is poor, check, clean, and replace air filter elements as needed.

## MAINTENANCE

### 3.2 Transporting

1. Shutdown engine for transportation.
2. For transportation, tighten fuel tank cap securely and close fuel cock to prevent fuel from spilling.
3. Drain fuel for transportation over long distance or bad road.
4. Secure machine firmly to prevent it from moving or tipping.
5. Rammer should be transported in such position as it is placed on level ground. In case of it must be laid down for transportation, drain fuel tank as well as carburetor and make sure that oil plug is tightened securely.
6. Direction to lay down the rammer, must be such that air cleaner comes to top. After laying it, make sure that there is no leak of oil or residual fuel.
7. Make sure lifting device has enough capacity to hold machine (see identification plate on machine for weight). Use central lifting point (a) when lifting machine.
8. Use trolley kit (supplied as optional) for short distance transportation.

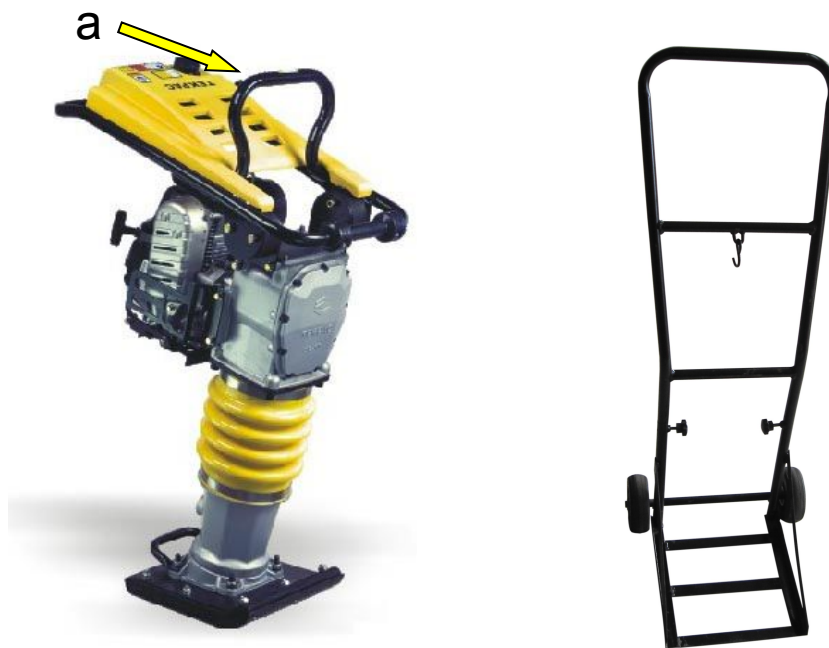

### 3.3 Spark Plug

Check and clean spark plugs regularly. A fouled, dirty spark plug may cause hard starting and poor engine performance. Set spark plug gap to recommended clearance. Refer to engine manual.



The muffler and engine cylinder become very hot during operation and remain hot for a while after stopping the engine. Allow engine to cool before removing spark plug.

NOTICE: A loose spark plug can become very hot and may cause engine damage.

## MAINTENANCE

### 3.4 Air Cleaner

Maintaining a clean engine will extend engine life. Keep air filter clean at all times. Clean air filter using the recommended solvent daily. See engine manual for proper cleaning procedure. Let the filter dry before reinstalling.



#### WARNING

NEVER use gasoline or other types of low flash point solvents for cleaning the air cleaner. A fire or explosion could result.

### 3.5 Storage

Rammer should be stored in such position as it is placed on level, after engine and machine have been cooled down. Be sure to secure the rammer as necessary to avoid falling down. If the rammer has to be laid down inevitably, tighten fuel tank cap and engine oil plug securely and wait until engine and machine are cooled down. After laying it down, make sure that there is no leak of fuel or oil. (If fuel leaks, drain the tank)

#### 3.5.1 Long-Term Storage

- Drain fuel from fuel tank, fuel line and carburetor.
- Remove spark plug and pour a few drops of motor oil into cylinder. Crank engine 3 to 4 times so that oil reaches all internal parts.
- Clean exterior with a cloth soaked in clean oil.
- Store unit covered with plastic sheet in moisture free and dust free location out of direct sunlight.

### 3.6 Troubleshooting

#### 3.6.1 Rammer Troubleshooting

SYMPTOM	POSSIBLE PROBLEM	SOLUTION
Engine rotates but amplitude not uniform or does not strike	Operating speed of throttle lever is incorrectly set?	Set throttle lever to correct position.
	Oil in excess?	Drain excess oil. Bring to correct level.
	Clutch slips?	Replace or adjust clutch.
	Spring Failure?	Replace spiral spring.
	Speed of engine improper?	Adjust engine speed to correct operating RPM setting.



## MAINTENANCE

### 3.6.2 Engine Troubleshooting

SYMPTOM	POSSIBLE CAUSE	SOLUTION
Difficult to start		
Fuel is available but spark plug will not ignite.(Power available at high tension code.)	Ignition plug being bridging?	Check ignition system.
	Carbon deposit at ignition?	Clean or replace ignition.
	Short circuit due to deficient insulator?	Replace insulators.
	Improper spark gap?	Set spark plug gap to the correct gap.
fuel is available but spark plug will not ignite.(Power NOT available at high tension code.)	Short circuit at stop switch?	Check stop switch circuit. Replace stop switch if defective.
	Ignition coil defective?	Replace ignition coil.
Fuel is available and spark plug ignites (compression normal).	Muffler clogged with carbon deposits?	Clean or replace muffler.
	Mixed fuel quality is inadequate?	Check fuel to oil mixture.
	Fuel in use inadequate (water, dust)?	Flush fuel system and replace with fresh fuel.
	Air cleaner clogged?	Clean or replac air cleaner.
Fuel is available and spark plug ignites (compression normal).	Defective cylinder head gasket?	Tighten cylinder head bolts or replace head gasket.
	Cylinder worn?	Replace cylinder.
	Spark plug loose?	Tighten spark plug.

## MAINTENANCE

SYMPTOM	POSSIBLE CAUSE	SOLUTION
Operation not satisfactory		
Not enough power available (compression normal, no missfiring)	Air cleaner clogged?	Clean or replace air cleaner.
	Air in fuel line?	Bleed (remove air) from fuel line.
	Fuel level in carburetor float chamber improper?	Adjust carburetor float.
	Carbon deposit in cylinder?	Clean or replace cylinder.
Not enough power available (compression normal, no missfiring)	Ignition coil defective?	Flush fuel system and replace with fresh fuel.
	Ignition plug often shorts?	Replace ignition wires, clean ignition.
	Fuel in use inadequate (water, dust)?	Flush fuel system and replace with fresh fuel.
Engine overheats.	Mixed fuel quality is inadequate?	Check fuel to oil mixture.
	Excessive carbon deposition in combustion chamber?	Clean or replace crankcase.
	Exhaust or muffler clogged with carbon?	Clean or replace muffler.
	Spark plug heat value incorrect?	Replace spark plug with correct type spark plug.
Rotational speed fluctuates.	Governor adjustment improper?	Adjust governor to correct lever.
	Governor spring defective?	Clean or replace ignition.
	Fuel flow erratic?	Check fuel line.
	Air taken in through suction line?	Check suction line.
Recoil starter not working properly.	Dust in rotating part?	Clean recoil starter assembly.
	Spiral spring failure?	Replace spiral spring.

## TECHNICAL DATA

### 4. TECHNICAL DATA

Model	SG70H	SG70R1	SG70R2	SG70LC	SG70C
Engine Type	Petrol, Honda GX100	Petrol, Robin EH10	Petrol, Robin ER12	Petrol, Loncin 165F-1H	Chinese Petrol Engine
Power kw(hp)	2.2(3.0)	2.2(3.0)	3.0(4.0)	3.0(4.0)	3.0(4.0)
Operation Mass kg(lbs)	65(144)	65(144)	65(144)	69(152)	70(154)
Percussion Rate per min.	650-695	650-695	650-695	650-695	650-695
Impact Force(KN)	11	11	13	13	13
Jumping Stroke mm	40-85	40-85	40-85	40-85	40-85
Fuel Tank Capacity l	2.8	2.8	2.8	2.8	2.8
Shoe Size mm(in)	330x285(13x11)	330x285(13x11)	330x285(13x11)	330x285(13x11)	330x285(13x11)
Dimension mm(in)	400X760X112	400X760X112	400X760X112	400X760X112	400X760X112

Model	SG80H	SG80R	SG80R2	SG80LC	SG80D
Engine Type	Petrol, Honda GX160	Petrol, Robin EH12-2D	Petrol, Robin EY20	Petrol, Loncin 168F-2H	Diesel, Kipor 170
Power kw(hp)	4.0(5.5)	3.0(4.0)	3.7(5.0)	3.0(4.1)	3.1(4.2)
Operation Mass kg(lbs)	70(154)	70(154)	72(158)	70(154)	80(176)
Percussion Rate per min.	650-695	650-695	650-695	650-695	650-695
Impact Force(KN)	14	13	13	13	13
Jumping Stroke mm	40-85	40-85	40-85	40-85	40-85
Fuel Tank Capacity l	2.8	2.8	2.8	2.8	2.8
Shoe Size mm(in)	330x285(13x11)	330x285(13x11)	330x285(13x11)	330x285(13x11)	330x285(13x11)
Dimension mm(in)	460X760X114	400X760X112	400X760X112	400X760X112	400X760X112

Model	TR65H	TR65R1	TR65R2	TR65R3
Engine Type	Petrol, Honda GX100	Petrol, Robin EH10	Petrol, Robin ER12	Petrol, Robin EH12-2D
Power kw(hp)	2.2(3.0)	2.2(3.0)	3.0(4.0)	3.0(4.0)
Operation Mass kg(lbs)	62(137)	62(137)	62(137)	67(148)
Percussion Rate per min.	650-695	650-695	650-695	650-695
Impact Force(KN)	11	11	13	13
Jumping Stroke mm	40-85	40-85	40-85	40-85
Fuel Tank Capacity l	2.8	2.8	2.8	2.8
Shoe Size mm(in)	330x285(13x11)	330x285(13x11)	330x285(13x11)	330x285(13x11)
Dimension mm(in)	400X760X112	400X760X112	400X760X112	400X760X112

Working Size mm:

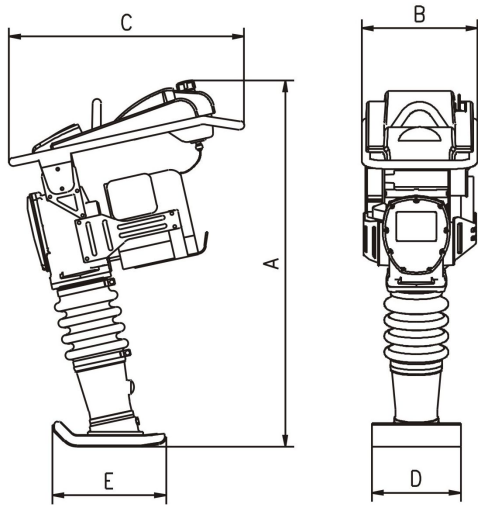

Model	A	B	C	D	E
SG70	1020	380	720	285	330
SG80	1020	440	720	285	330
TR65	1020	400	720	285	330

Sound Specification (According to 2000/14/EC)

Measured sound Power level	105 dB(A)
Guaranteed sound power level	108 dB(A)

**Hand-Arm vibration** Specification (According to ISO 5394, EN 1033 and EN500-4):  
8.0m/s<sup>2</sup>

## WARRANTY

Our products are covered by warranty for a period of twelve (12) months from the date of purchase against defects in material or workmanship provided that:

- The product concerned has been operated and maintained in accordance with the operating instructions.
- Has not been damaged by accident, misuse or abuse.
- Has not been tampered with or repaired by any unauthorized person.

The owner is responsible for the cost of transportation to and from the authorized repairer and the unit is at the owners risk while in transit to and from the repairer.

**Impact damage is not covered under warranty. Clutches are not covered under any warranty.**

**Engines are officially guaranteed by Honda, Robin, Loncin manufacturer. Please refer to the annex for engine warranty.**



**Distributed By**

